



# **85M Bandsaw**

## **Instruction Manual**

# Index

<u>Safety procedures for the operator</u>	<u>3</u>
<u>Operating instructions</u>	<u>3</u>
<u>Adjusting the blade tension</u>	<u>3</u>
<u>Adjusting the blade guide</u>	<u>4</u>
<u>Running in the blade</u>	<u>4</u>
<u>Adjusting the stop bar</u>	<u>4</u>
<u>Adjusting the cutting angle</u>	<u>4</u>
<u>Changing the blade</u>	<u>4</u>
<u>Choosing the cutting speed</u>	<u>6</u>
<u>Choosing the blade</u>	<u>6</u>
<u>Correct positioning of the piece in the clamp</u>	<u>6</u>
<u>Locking device for transport</u>	<u>6</u>
<u>Maintenance</u>	<u>6</u>
<u>Cutting table</u>	<u>7</u>
<u>Spare parts</u>	<u>7</u>
<u>Wiring diagram</u>	<u>7</u>
<u>Electrical data</u>	<u>7</u>

## Safety procedures for the operator

Before starting to work with your band saw, read this manual carefully so that you can use the machine you have just bought better and with maximum safety.

- Keep your work surface clean: cleanliness in the cutting area is essential if you are to work in safety.
- Avoid dangerous exposure: Do not use the machine in very damp places, or near inflammable liquids or explosive gases.
  - Do not force the machine unnecessarily: in order to obtain the best performance, follow the instructions given in this booklet. Too high a pressure on the piece to be cut may cause rapid deterioration of the blade and harmful overheating of the motor. For recommended cutting times, see the cutting table.
- Dress suitably: do not wear wide-sleeved clothes or accessories such as scarves, necklace or bracelets that could be caught in the moving parts.
- Always use the clamp: the pieces to be cut must always be held still with the clamp. Never hold with your hand piece that are to be cut.
- Avoid accidental starts: do not keep pressed the button on the grip, while inserting the plug in the socket. Make sure the main switch is in "o" position.
- Check the machine: before starting each cutting operation, ensure that all the parts of the machine are whole and that protection are in safety position.
- Information on noise (EEC directive 09/392): in normal conditions of use, the cutting machine produce the following sound pressure level equivalent values:
  - Leq = 82 dB (A), when running idle
  - Leq = 87,5 dB (A), when working

We recommend the use of personal means of ear protection, such as earmuffs or earplugs.

## Operating instructions

When delivered, your band saw has already undergone a strict inspection and is able to offer the best performance. However, before starting work, you must adjust the blade tension and run the blade in.

### 1. Adjusting the blade tension (Fig.1)

Carefully proceed as follows: a correct blade tension is fundamental if you are to get the best performance from your band saw. Ensure that the switch is in "0" position. Turn the handwheel(B) clockwise as far as it can go, but without blocking it completely. While holding the handwheel(B) still, turn the knob(C) anticlockwise until it locks.

**N.B. if tension is too high, the blade tends to escape from the guides.**

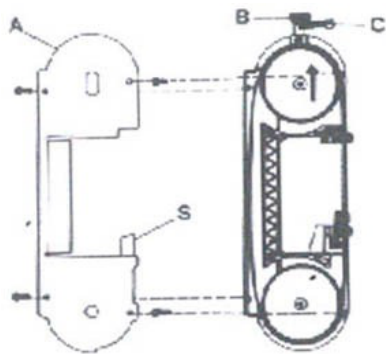

Fig.: 1

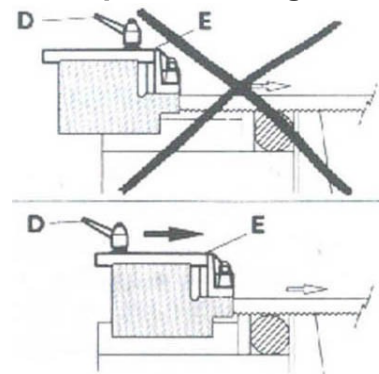

Fig.: 2

## 2. Adjusting the blade guide

Your cutting machine is provided with a sliding guide (E) with built-in protection, which guides the part of the blade necessary to make the cut, and at the same time, protects the part of the blade not in use. To do this, simply slacken the handle (D) and slide the blade guide (E) so as to bring it closer to or farther from the piece that is to be cut (as clearly shown in fig.2).

## 3. Running in the blade

To safeguard the life and quantity of a new blade, the first two or three cuts must be made exerting slight pressure on the piece so that the cutting time is almost twice the one normally needed (see cutting table).

## 4. Adjusting the stop bar (fig.3)

If you have to cut several pieces, all the same length, use the stop bar provided with the band saw, in order to avoid repeating the measurements. Insert the rod (F) in the hole in the base and block it with the tow nuts. Slacken the handwheel (B) and place the stop (H) at the necessary distance from the blade. Then lock the handwheel (G).

## 5. Adjusting the cutting angle

The band saw can cut an angle varying from  $0^\circ$  to  $45^\circ$  : It is sufficient to slacken the nut (I) with a 17mm spanner and turn the rotating support (L) towards the corresponding limit stops (M) and (N). For all other intermediate angles, turn the rotating support until the mark (O) on the support matches the corresponding position in the plate. Then lock the rotating support again with the nut (I).

## 6. Blade replacement

Whenever the blade is worn, or whenever you need one with different tothing (see Choosing the blade, point 7), it must be replaced with a more suitable one.

· Slacken handle D (fig.2) and slide blade guide E as far as it will go, following

the direction of the arrow in fig.2.

- Remove protective casing A, by unscrewing the four screws.
- Slacken the blade tension, turning knob C (fig.1) clockwise until it stops, and handwheel B anticlockwise.
- Using a 10mm-spanner, slacken the hexagonal nuts P on the two blade guide on the outside of the blade (fig.5).
- With the same spanner, gently turn the head of the screws Q on the same blade guide anticlockwise, so as to move the bearings far away enough from the blade and therefore enable you to extract it easily from the guides.
- Pull the blade out of the guides first, and then out of the rubber-coated pulleys.
- Insert the new blade first between the guides and then onto the rubber-coated pulleys, with the teeth facing as shown in fig.6.
- Put the blade under tension again, as described in point 1, and reposition the two outer blade guides in slight contact with the blade, turning the head of the screw Q clockwise.
- Lock the two hexagonal nuts P again.
- Replace protective casing A, being careful to insert the blade between the straps of the protection S(see fig.1.).
- Reposition blade guide E in the correct position for the next cut(see point 2).

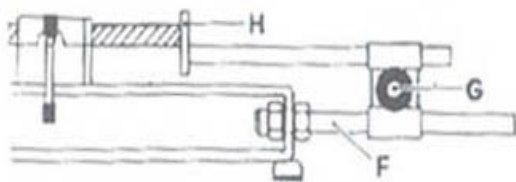

Fig.: 3

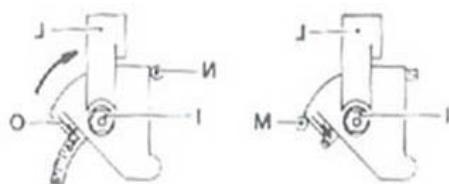

Fig.: 4

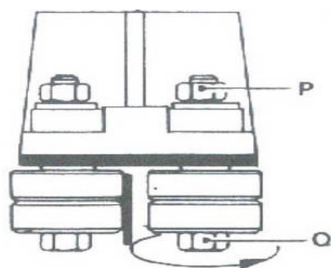

Fig.: 5

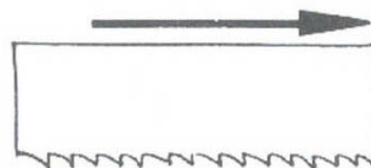

Fig.: 6

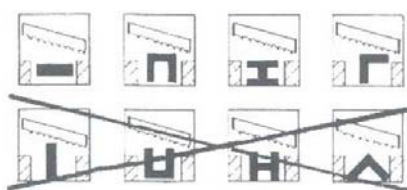

Fig.: 7

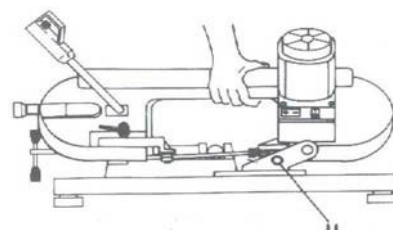

Fig.: 8

## 7. Choosing the cutting speed (only No. 1811000)





This version can perform at two different speeds. In this way, you can always choose the speed most suitable to the material to be cut, regulating it by means of the variator.

## 8. Choosing the blade

The choice of the right blade and its toothing depends on the type of material you have to cut and on its section. Your band saw is fitted with a 1325x13mm, 0.65mm thick metal blade, with variable tooth formation of 8-12 teeth per inch, which can perform most of the cuts possible with this machine. However, blades with 6 or 14 teeth per inch are also available for special cutting requirements, as indicated in the "cutting table".

## 9. Correct positioning of the piece in the clamp

Pieces to be cut must always be held firmly in the clamp, directly between the two jaws and without inserting other objects. Were profiles, flat bars or particular shapes to be cut, refer to the examples in fig.7.

 30 50 85 max	8/12	60	0'40"
	6	60	2'00"
	6	60	5'00"
 30 50 85 max	8/12	60	1'10"
	6	60	3'10"
	6	60	8'00"
 25x35 40x50 85x105 max	8/12	60	1'10"
	6	60	2'30"
	6	60	11'00"
 30xs.1 40xs.2 50xs. 5 max	14	80	0'05"
	14	80	0'15"
	8/12	60	0'50"
 30xs.1 50xs.2	14	80	0'10"
	14	60	0'30"

## 10. Locking device for transport

Your cutting machine is provided with a locking device, which allows you to transport it from one place to another. It is sufficient to insert the pin(U) in the hole in the body, and then lift the machine, gripping it as shown in fig.8.

## Maintenance

- Be careful: before every cleaning or maintenance operation, ensure that the plug is not in the electric supply socket.
- Keep the cutting machine free from residue by means of a vacuum cleaner

or a brush, passing it also over the blade guides and the rubber-coated pulleys.

- Keep the band saw in good conditions: if it is not to be used for a long time, put it away in its original packing in a damp-free place. In these cases it is advisable to slacken the blade so as not to keep it under tension unnecessarily.

## Spare parts

Together with this manual you can find the exploded views showing all the components of the band saw. Refer to these drawings to identify any spare parts you may need.

The data in the present table is approximate.

## Electrical data

Take into account that, upstream from the mains to which the cutting machine is connected, there must be a suitable magneto thermal protected to safeguard all the leads against short-circuits and overloads. This protection device must be chosen according to the electric characteristics of the machine as shown below.

Rated voltage	220~240 Volt
	110~120 Volt
Rated current	4.2 Amp
Absorbed power	1000 Watt
Max. ad. Overload(30sec.)	5 Amp

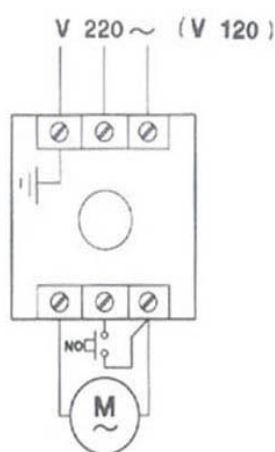
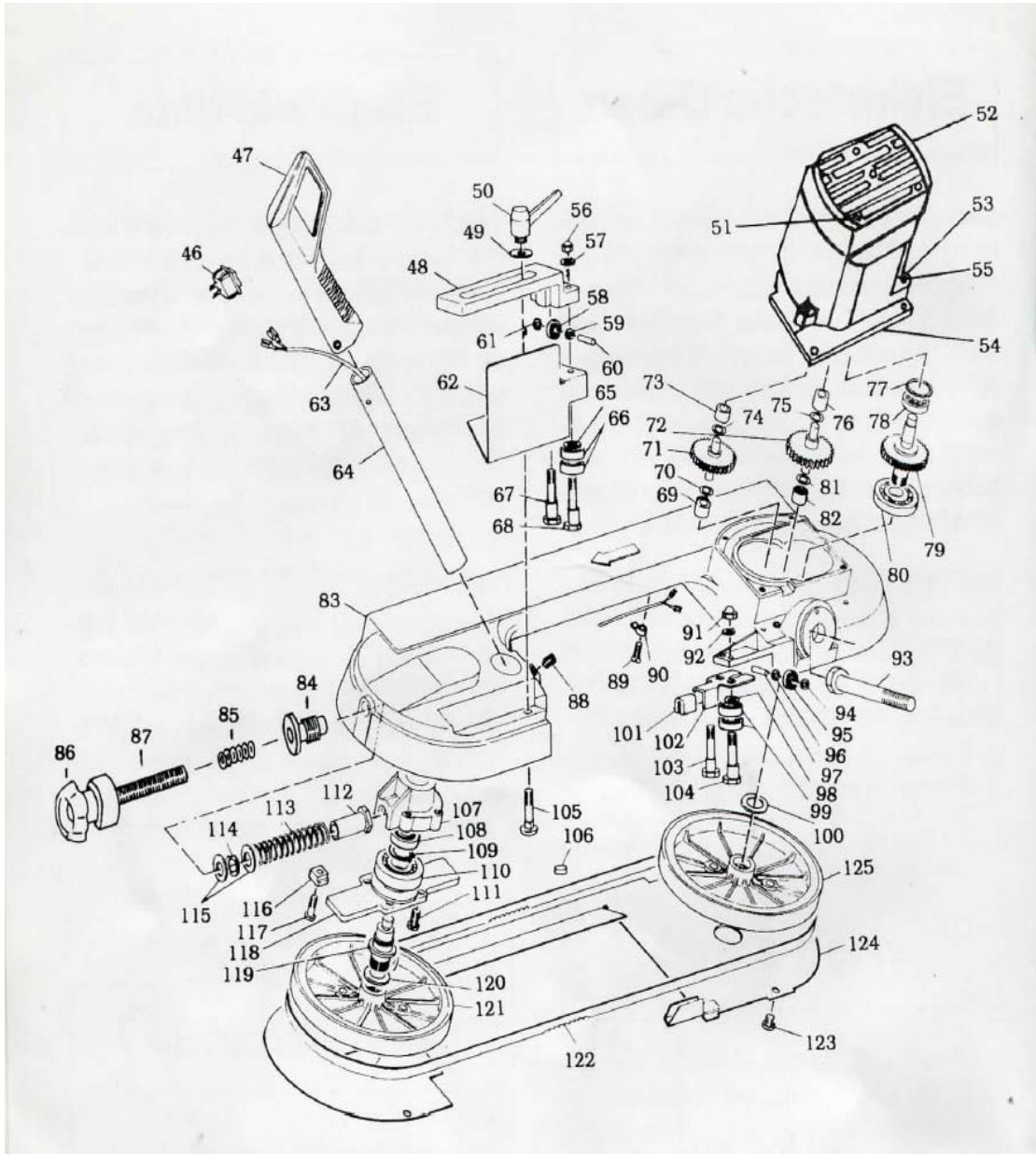
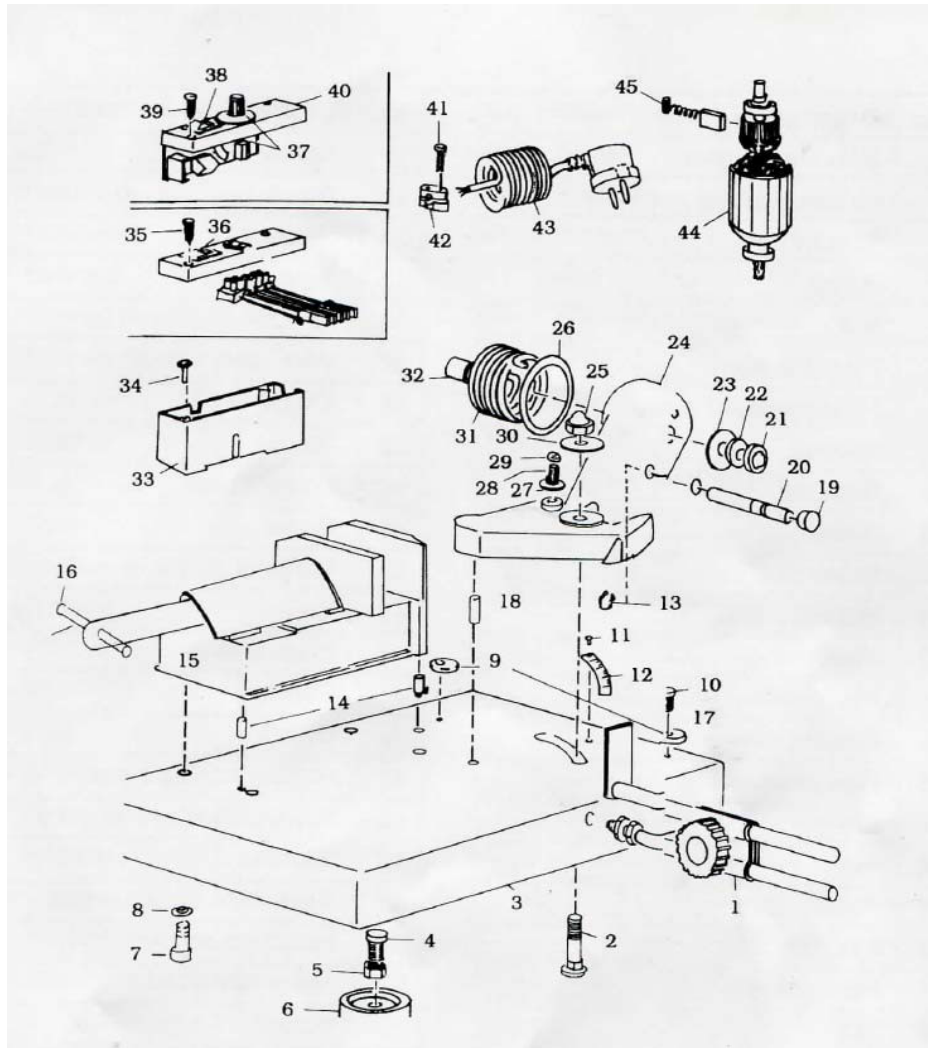

Fig.: 9





No.	Description	No.	Description	No.	Description
1	Balance support	45	Carbon	89	Screw
2	Hexagon screw head	46	Switch	90	Plastic cover
3	Bottom	47	Rubber handle cover	91	Hexagon nut
4	H.H.S.	48	Adjustable blade length	92	Washer
5	Nut	49	Washer	93	Hexagon rod
6	Plastic bottom	50	Blade tension adjustable	94	Screw
7	Hexagon head screw	51	Handless screw	95	Beating
8	Washer	52	Motor cover	96	Screw
9	Stopper	53	Screw	97	Rod
10	Screw	54	Plastic case	98	Washer
11	Scale	55	Bush	99	Bearing
12	Nut	56	Hexagon nut	100	Washer

13	Plastic ring	57	Washer	101	Carpet
14	Pin	58	Bearing	102	Flexible bearing plate
15	Casting vice	59	Screw	103	Rod screw
16	Plastic cover	60	Pin	104	Rod screw
17	Pin	61	Screw	105	Round rod screw
18	Pin	62	Protect blade cover	106	Nut
19	Plastic cover	63	Wire	107	Bearing cover
20	Pin	64	Handle pivot	108	Bearing
21	Hexagon nut	65	Washer	109	Washer
22	Nut	66	Bearing	110	Bearing
23	Washer nut	67	Bearing flexible rode	111	Hexagon headless screw
24	Support	68	Bearing flexible rode	112	Hexagon head screw
25	Hexagon nut	69	Bush	113	Spring
26	Washer	70	Washer	114	Washer
27	Washer	71	Gear	115	Washer
28	Support screw	72	Gear	116	Angle lock nut
29	Nut	73	Bush	117	Headless screw
30	Washer	74	Washer	118	Lock plate
31	Spring	75	Washer	119	Inner hexagon screw
32	Screw	76	Bush	120	Washer
33	Power box	77	Ring	121	Pulley wheel
34	Screw	78	Bearing	122	Blade
35	Screw	79	Gear	123	Screw nut
36	On Off	80	Bearing	124	Blade back safety cover
37	Wire cord	81	Gear	125	Pulley wheel
38	On Off	82	Bush		
39	Screw	83	Aluminum body frame		
40	Power cover	84	Blade tension adjusting handle		
41	Screw	85	Sping		
42	Connect plastic cover	86	Plastic cover		
43	Wire	87	Rod		
44	Electric body	88	Headless screw		