



# Super Lux Plus

## Instruction Manual



Chester UK Ltd  
Clwyd Close  
Hawarden Industrial Park Hawarden  
Chester CH5 3PZ  
Tel: 01244 531631  
[sales@chestermachinetools.com](mailto:sales@chestermachinetools.com)  
[www.chestermachinetools.com](http://www.chestermachinetools.com)

**WARNING: FAILURE TO FOLLOW THESE RULES MAY RESULT IN  
SERIOUS PERSONAL INJURY**

As with all machinery there are certain hazards involved with operation and use of the machine. Using the machine with respect and caution will considerably lessen the possibility of personal injury. However, if normal safety precautions are overlooked or ignored, personal injury to the operator may result.

This machine was designed for certain applications only. We strongly recommend that this machine should NOT be modified and/or used for any application other than for which it was designed. If you have any questions relative to its application DO NOT use the machine until you have had detail instruction form your dealer.

**Safety rules for all tools**

- For your own safety, read this instruction manual before operating the machine tool. Learn the tool's application and limitations as well as the specific hazards peculiar to it.
- Keep guards in place and in working order.
- Ground all tools. If tool is equipped with three-prong plug, it should be plugged into a three-hole electrical receptable, the adapter plug must be attached to a known ground. Never remove the third prong.
- Remove adjusting and wrenches. Form a habit of checking to see that keys and adjusting wrenches are remove from the machine tool before turning it on.
- Keep work area clean. Cluttered areas and benches can cause accidents.
- Don't use in dangerous environments. Don't use power tools in damp or wet locations, or expose them to rain. Keep work area well-lit.
- Keep children and visitors away. Keep any persons a safe distance from work area.
- Make workshop childproof. Use padlocks, switches, or remove starter keys.
- Don't force machine tool. It will work better and be safer at the rate for which it was designed.
- Use the correct tool. Don't force machine tool or attachments to do a job for which it was not designed.
- Wear proper apparel. No loose clothing, gloves, neckties, rings, bracelets, or other jewellery. This will get caught in moving parts. Wear non slip footwear and protective hair covering.
- Always wear eye protection. Refer to ANSIZ87.1 standard for appropriat recommendations. Also use face or dust mask if cutting operation is dusty.
- Secure work. Use clamps or a vice to hold work when practical. It's safer than working by hand and free's both hand to use the machine tool.
- Don't over reach. Keep proper footing and balance at all times.
- Maintain machine tools. Keep in good condition. Keep tool sharp and clean for best performance. Follow instructions for lubricating and changing accessories.
- Disconnect tools before servicing and when changing accessories such as blades, cutters, etc..
- Use recommended accessories. Consult the owner's manual for recommended accessories. The use of improper accessories may cause hazards.
- Avoid accidental starting. Make sure switch is in off position before plugging in.
- Never stand on tool. Serious injury could occur is the tool is tipped or if the cutting tool is

accidentally contacted.

- Check damaged parts. Before using the tool, a guard or other part that is damaged should be checked to ensure that it will operate properly and perform its intended function. Check for alignment of moving parts, binding of moving parts, breakage of parts mounting, and any other conditions that may affect its operation. A guard or any other part that is damaged should be properly repaired or replaced.
- Direction of feed. Feed work into a blade or cutter against the direction of rotation of the blade or cutter only.
- Never leave machine tool running unattended. Turn power off. Let machine come to a complete stop before leaving.
- Drugs, alcohol, and medication. Do not operate machine tool whilst under the influence of drugs, alcohol, or medication.
- Make sure machine tool is disconnected from power supply whilst motor is being mounted, connected, or reconnected.

## ADDITIONAL SAFETY RULES FOR MILL DRILL

1. Ensure drill bit or cutting tool is securely locked in the chuck.
2. Ensure chuck key is remove form the chuck before turning on power.
3. Adjust the table or depth stop to avoid drilling into the table.
4. Shut off the power, remove the drill bit or cutting tool, and clean the table before leaving the machine.
5. CAUTION. When practical, use clamps or a vise to secure workpiece to keep the workpiece form rotating while the drill bit or cutting tool.
6. WARNING: FOR Your Own Safety, Don't wear gloves when operating a mill/drill.

## Machine specifications

Model		Super Lux Plus	
Drilling capacity	cast iron	32mm	
	mild steel	25mm	
Face mill capacity		76mm	
End mill capacity		25mm	
Working table size		800mm X 240mm	
Working table cross travel		190mm	
Working table longitudinal travel		560mm	
T-slot size		14mm	
Head tilt left right		90°	
Head swivel			
Spindle taper(option)		MT4	
Max distance spindle to table		420mm	
Spindle stroke		120mm	
Spindle speed(rpm) (option)	Motor: I .5KW 5- 100Hz I 3PH	L	75-435rpm
		H	435-2500rpm
Overall dimension			
Packing dimension		1240mmx760mmx1 150mm	
NW/GW Weight		3501385Kg	

**WARNING: CHANGE SPEED ONLY WHEN MACHINE IS STOPPED**  
**CHANGING THE GEAR BOX OIL**

Tilt the head stock over as shown in Fig 1. Open the drain plug to allow the oil to drain from the opening completely. Then lock the oil drain plug and turn the head to be upright position. Remove the oil filler plug fill the oil to the gear until the oil level reach the middle of oil fluid level indicator. Then lock the plug.

## **CLEANING**

- (1) Your machine has been coated with a heavy grease to protect it in shipping. This coating should be completely removed before operating the machine. Commercial degreaser, kerosene or similar solvent may be used to remove the grease from the machine, but avoid getting solvent on belts or other rubber parts.
- (2) After cleaning, coat all bright work with a light lubrication. Lubricate all points with a medium consistency machine oil.

## **LUBRICATION:**

All ball bearings in your mill/drill are sealed for life, requiring no lubrication. Points requiring lubrication are:

- (1) Internal spline drive assembly. Keep this area well lubricated with a good grade grease, insert grease in the hole at the top of spindle pulley spline driver, lube twice yearly.
- (2) A light film of oil applied to the quill and column will reduce wear, prevent rust, and assure ease of operation.
- (3) Quill return spring should receive oil (iso 20) once yearly. Remove cover plate and apply oil with squirt can or small brush.
- (4) **IMPORTANT:** The gear box lubrication oil: 32# mechanical oil, 3L.  
CHANGE OIL EVERY ONE YEAR
- (5) Apply lubricant to quill pinion every 90 days.

NOTE: use extreme care when performing this operation and keep hands clear of pinch points. When using paraffin bar, do this only by turning the sheaves by hand. Do not apply with motor running.

## **USE OF MAIN MACHINE PARTS**

- (1) To raise and lower the head-by-head handle.
- (2) Equipped with an electric switch for tapping operation clockwise or counter clockwise.
- (3) To adjust the quick or slow feeding by feed handle.
- (4) To adjust the table left and right travel by table handle wheel.
- (5) To adjust the table fore and after travel by table handle wheel.
- (6) To operate the spindle handle wheel for micro feed.
- (7) To adjust the scale size according to working need.

## **PRECAUTION OPERATION**

Check all parts for proper condition before operation; if normal safety precautions are noticed carefully, this machine can provide you withstanding of accurate service.

**(1) Before Operation**

- (a) Fill the lubricant
- (b) In order to keep the accurate precision, the table must be free from dust and oil deposits.
- (c) Check to see that the tools are correctly set and the workpiece is set firmly.
- (d) Be sure the speed is not set to fast.
- (e) Be sure everything is ready before use

**(2) After Operation**

- (a) Turn off the electric switch.
- (b) Turn down the tools.
- (c) Clean the machine and coat it with lubricant.
- (d) Cover the machine with cloth to keep out the dust.

**(3) Adjustment of head**

- (a) To raise and lower the head, loosen the leaf screw located on the right side of the raise and lower base. When the desired height is reached tighten leaf screw to avoid vibration.
- (b) Unscrew 3 nuts while the workpiece needs to be bevel turn to the degrees you wish on the scale, then screw the 3.

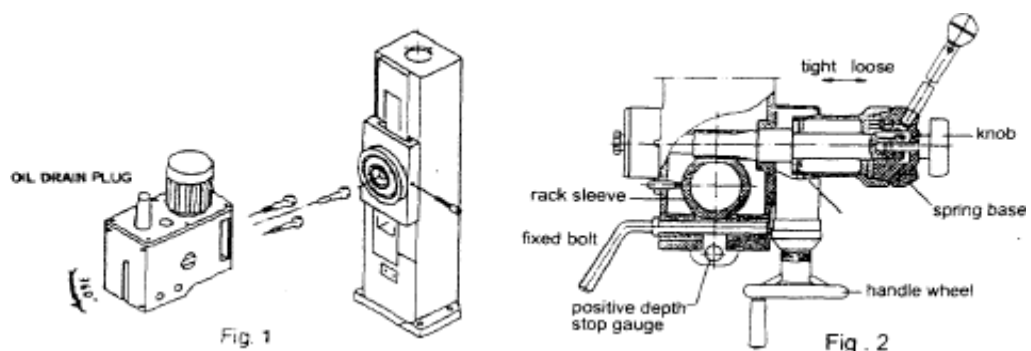

**QUILL RETURN SPRING ADJUSTMENT:**

Spring tension for return of spindle, after hole drilling, has been pre-set at the factory. No further adjustment should be attempted unless absolutely necessary. Adjustment will probably be required if a multiple spindle drilling or tapping head is used. If adjustment is necessary, loosen lock screw while holding quill spring housing. Do not allow the housing to turn in your hand, or spring will unwind. Turn entire housing assembly clockwise the number of turns necessary to cause the quill to return to its up position. (NOTE: The flat of the spring housing pilot is lined up with the spring loading hole on the

body of the spring housing.) Reset lock screw make sure point of screw mates the flat on the housing journal.

- (1) Preparing for Drilling (see fig.2) (Except addition power feed system). Turn of the knob make loose the taper body of worm gear and spring base. Then we decide spindle stroke setting the positive depth stop gauge for drilling blind hole or free state for pass hole.
- (2) Preparing for milling (see fig.2) (Except addition power feed system)
  - (a) Adjust the positive depth stop gauge to highest point position.
  - (b) Turn tight of the knob being used to taper friction force coupling the worm gear and spring base. Then turning the handle wheel by micro set the spindle of work piece machining height.
  - (c) Lock the rack sleeve at the desired height with fixed bolt.

ADJUSTING TABLE SLACK AND COMPENSATE FOR WEAR (see fig.3)

- (1) Your machine is equipped with jib strip adjustment to compensate for wear and excess slack on cross and longitudinal travel.
- (2) Clockwise rotation the job strip bolt with a big screw for excess slack otherwise a little counter clockwise if too tight.
- (3) Adjust the jib strip bolt until feel a slight drag when shifting the table.

CLAMPING TABLE BASE AND MACHINE BASE (See Fig.3)

- (1)When milling longitudinal feed. It is advisable to lock the cross feed table travel to ensure the accuracy of your work. To do this, tighten the small leaf

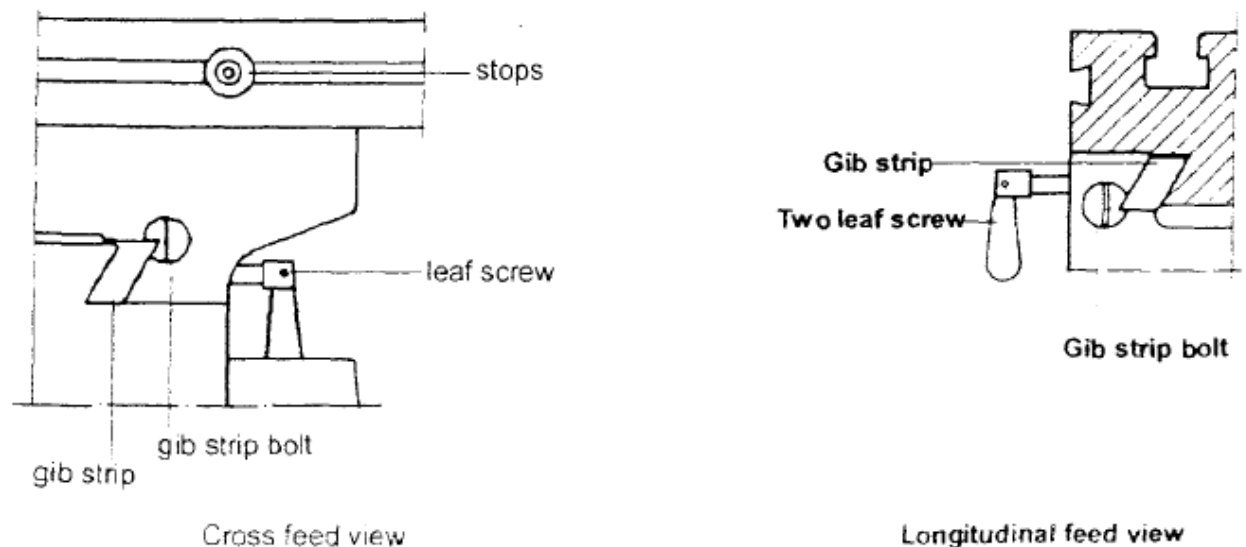

Fig.3

(2) To tighten the longitudinal feed travel of the table for cross feed milling, tighten the two small leaf screw on the front of the table base. (3) Adjustable travel stops are provide on the front of the table for control of cross travel and the desired milling length.

### TO CHANGE TOOLS

#### (1) Removing Face Mill or Drill Chuck Arbor

Loosen the arbor bolt at the top of the spindle shaft approximately 2 turns with a wrench. Tap the top of the arbor bolt with a mallet.

After taper has been broken loose, holding chuck arbor on hand and turn detach the arbor bolt with the other hand.

#### (2) To install Face Mill or Cutter Arbor

Insert cutter and cutter arbor bolt detach securely, but do not over-tighten.

#### (3) Removing Taper Drills

(a) Turn down the arbor bolt and insert the taper drill into the spindle shaft.

(b) Turn the rapid down handle rod down until the oblong hole in the rack sleeve appears. Line up this hole with the hole in the spindle. Insert key punch key through holes and strike lightly with a mallet. This will force the taper drill out.

### SPECIFICATION OF T-SLOT

The size of T-Solt on table as fig.4

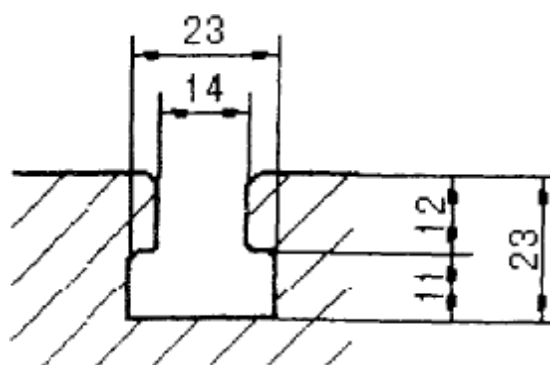

Fig.4

## TROUBLE SHOOTING HINTS

TROUBLE	PROBABLE CAUSE	REMEDY
Excessive Vibration	<ol style="list-style-type: none"> <li>1. Motor out of balance</li> <li>2. Bad motor</li> </ol>	<ol style="list-style-type: none"> <li>1. Balance or replace problem motor.</li> <li>2. Replace motor</li> </ol>
Motor stalls	<ol style="list-style-type: none"> <li>1. Over feeding.</li> <li>2. Dull drill.</li> <li>3. Motor not building up to running speed.</li> <li>4. Bad motor</li> </ol>	<ol style="list-style-type: none"> <li>1. Replace feed rate.</li> <li>2. Sharpen drill and keep sharp.</li> <li>3. Replace or repair motor. Check fuses in all three legs on three phase motors and replace if necessary.</li> <li>4. Replace motor</li> </ol>
Noisy Operation	<ol style="list-style-type: none"> <li>1. Excessive vibration</li> <li>2. Improper quill adjustment.</li> <li>3. Noisy spline.</li> <li>4. Noisy motor</li> </ol>	<ol style="list-style-type: none"> <li>1. Check remedy under excessive vibration.</li> <li>2. Adjust quill.</li> <li>3. Lubricate spline.</li> <li>4. Check motor bearing or for loose motor fan.</li> </ol>
Drill or Tool heats up or burns work	<ol style="list-style-type: none"> <li>1. Excessive speed.</li> <li>2. Chips not clearing.</li> <li>3. Dull tool.</li> <li>4. Feedrate too slow.</li> <li>5. Rotation of drill incorrect.</li> <li>6. Failure to use cutting oil or coolant (on steel)</li> </ol>	<ol style="list-style-type: none"> <li>1. Reduce speed.</li> <li>2. Use pecking operation to clear chips.</li> <li>3. Sharpen tool or replace.</li> <li>4. Increase feed enough to clear chips.</li> <li>5. Reverse motor rotation.</li> <li>6. Use cutting oil or coolant on steel</li> </ol>
Drill leads off	<ol style="list-style-type: none"> <li>1. No drill spot.</li> <li>2. Cutting lips on drill off center.</li> <li>3. Quill loose in head.</li> <li>4. Bearing play.</li> </ol>	<ol style="list-style-type: none"> <li>1. Center punch or center drill workpiece.</li> <li>2. Re grind drill.</li> <li>3. Tighten quill.</li> <li>4. Check bearings and reseal or replace if necessary.</li> </ol>
Excessive drill runout or wobble	<ol style="list-style-type: none"> <li>1. Bent drill.</li> <li>2. Bearing play.</li> <li>3. Drill not seated properly in chucks.</li> </ol>	<ol style="list-style-type: none"> <li>1. Replace drill. Do not attempt to straighten.</li> <li>2. Replace or reseal bearings.</li> <li>3. Loosen, reseal and tighten chuck.</li> </ol>
Work or fixture comes loose or spins	<ol style="list-style-type: none"> <li>1. Failure to clamp workpiece or work holding device to table.</li> </ol>	<ol style="list-style-type: none"> <li>1. Clamp workpiece or work holding device to table surface.</li> </ol>

### Power feed device

This machine be equipped with the power feed device see Fig.1.

- 1.Power feed switch
- 2.Speed lever
- 3.Spindle stroke dial
4. Handle
- 5.Limited screw
- 6.Locked nut
- 7.Micro feed dial
- 8.Lock screw
- 9.Hand wheel

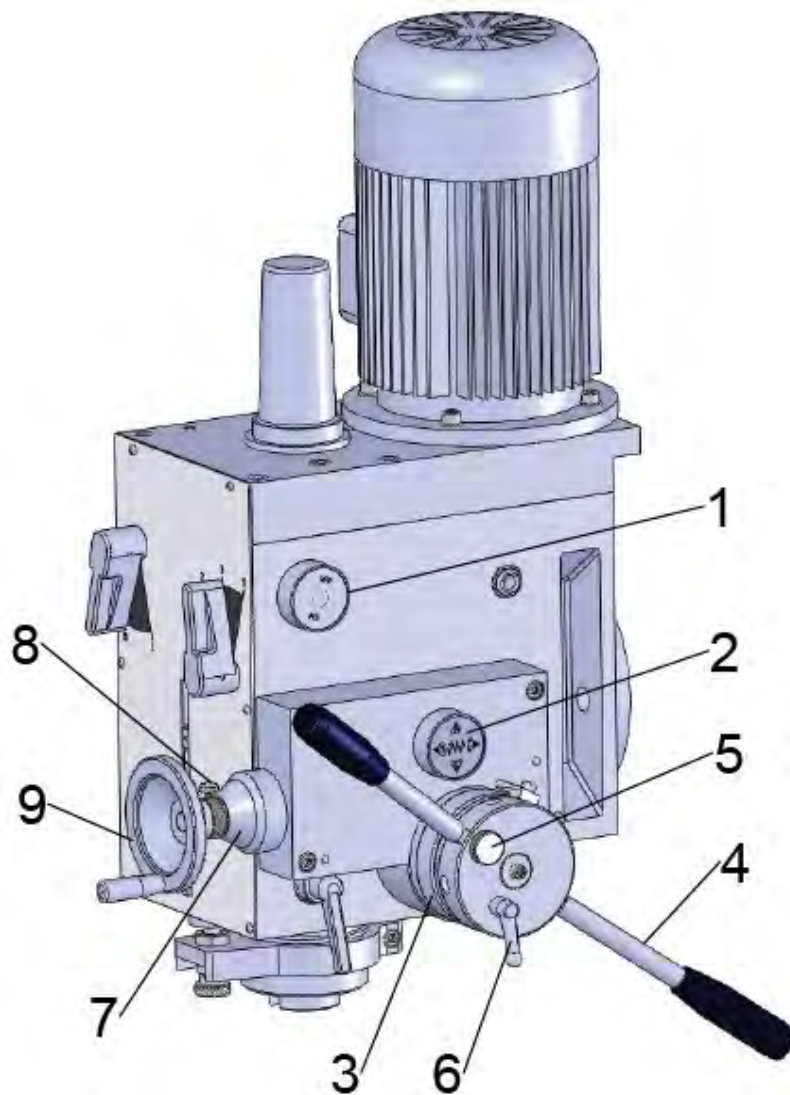

## **OPERATION PROCEDURE**

### **Manual feed**

Turn the power feed switch 1 off, handle 4 with be vertical with the axis of Spindle stroke dial 3, rotate limited screw 5 and be contacted with handle 4, then can be manually feed spindle.

When the power feed switch 1 on, make handle 4 vertical, locked limited screw 5, rotate Speed lever 2 to "0" , then can be manually feed spindle.

When want to trade off manually feed and power feed, stop the machine and turn on power feed switch 1 and speed lever 2. Make handle 4 vertical can be manually feed Spindle, Push handle 4 right can be power feed Spindle.

### **Power feed**

Turn on Power feed switch 1 and Speed lever 2, Start the machine and push handle 4 right can be power feed spindle, the machine can be automatically shut down when spindle arrived at the designed Depth. (max Depth 120mm, availability Depth 115mm), and spindle send back. Turn Speed lever 2 can realize 0.10, 0.18, 0.26 three kinds of depth feed to choose.

Want to make the machine spindle direct into power fed, loose locknut 6, make Spindle stroke dial 3 to max stroke depth dial position, tighten locknut 6 form Spindle stroke dial 3 can read spindle the position.

### **Adjustment power feed depth**

Move spindle to the designed position, shut down the machine. Push handle 4 right, loose locknut 6, adjusted Spindle stroke dial 3, make the designed dial level with "0", locked Spindle stroke dial 3, start the machine can power feed. Automatically shut down when spindle arrived at the designed Depth, and spindle send back. During power feed, make handle 4 vertical can stop power feed. Make handle 4 vertical can stop power feed. Need to use micro feed device, rotate Speed lever 2 to "0", push handle 4 right, loose lock screw 8, adjust micro feed dial 7 to "0", tighten lock screw 8, rotate hand wheel 9 can realize micro feed.

The system has a safety clutch device which is set before leaving the factory. When clutch is invalid because of fray, and needs to be adjusted, take away the panel and adjust spring which immediately recovers this function.

Parts list

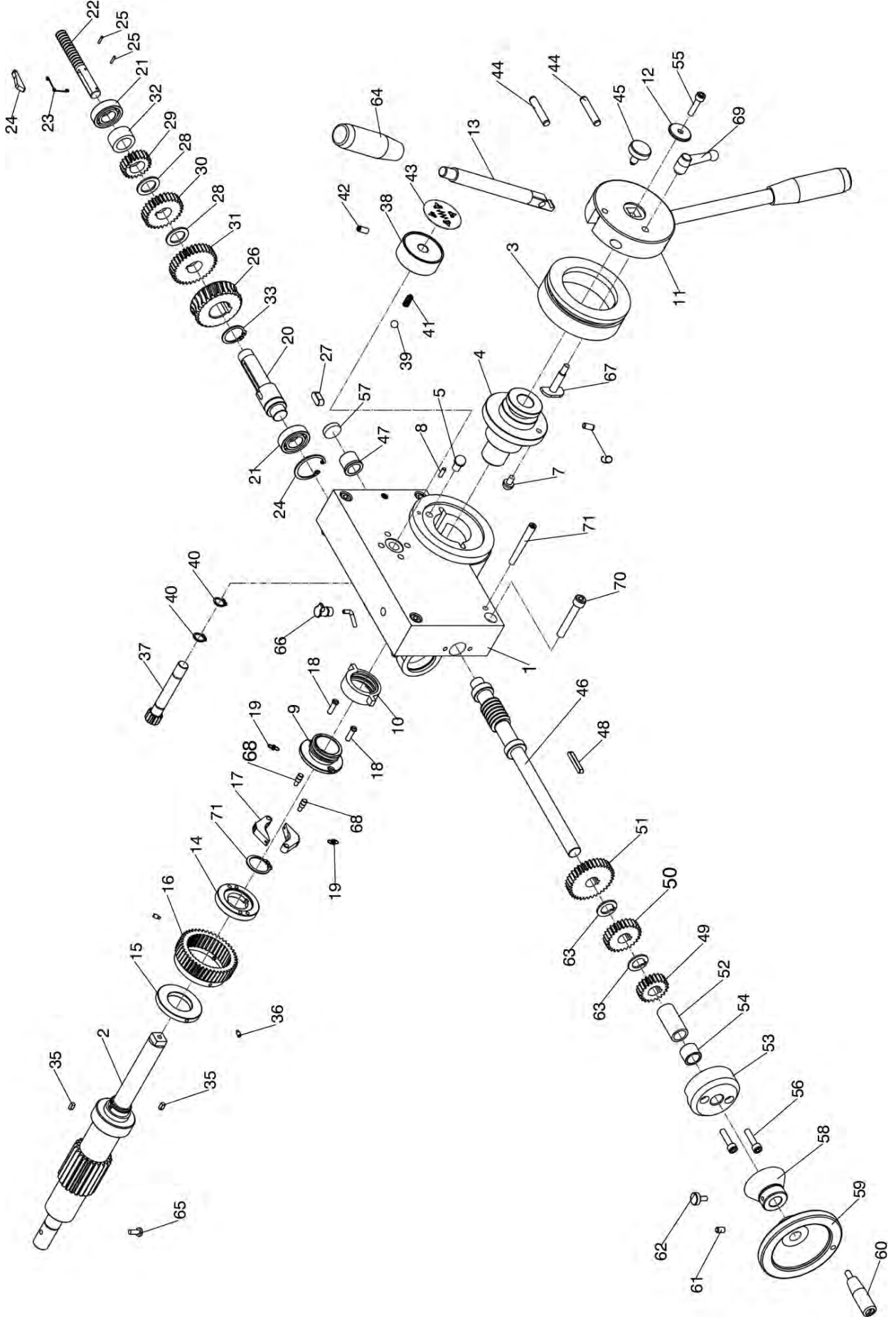

No	Code	Qty.	Name	No	Code	Qty.	Name
1	20102	1	Feed box	38	20201	1	Speed lever
2	20234	1	Pinion shaft	39		1	Steel ball 8
3	20243	1	Spindle stroke dial	40		2	Retainer ring 12
4	20242	1	Clutch bushing set	41		1	Spring
5	20241	1	Backing pin	42		1	Screw M6 X 20
6		1	Pin 6 X 12	43	20303	1	Plate
7	20247	1	Ball head pin	44	20206	2	pin
8		2	Pin 4 X 10	45	20204	1	Limited screw
9	20239	1	Square thread set	46	20233	1	Worm shaft
10	20240	1	Square thread nut	47	20306	1	Bush
11	20244	1	Handle body	48		1	Key
12	20245	1	Washer	49	20228	1	Gear
13	20203	2	Handle	50	20229	1	Gear
14	20237	1	Clutch key base set	51	20230	1	Gear
15	20236-2	1	Bush	52	20106	1	Bush
16	20236-1	1	Worm gear	53	20227	1	Worm cover
17	20231	2	Clutch screw set	54	20305	1	Bush
18	20235	2	Screw	55		2	Screw M6 X 12
19	20232	2	Sping	56		2	Screw M6 X 25
20	20223	1	Il shaft	57	20107	1	Plate
21		2	Bearing 6003	58	20226	1	Micro feed dial
22	20215	1	Change gear lever set	59	20105	1	Hand wheel
23	20220	1	Spring	60		1	Hand
24	20222	1	Pull key	61		1	Screw M5 X 8
25		2	Pin 2 X10	62		1	Locked screw M5 X 12
26	20304	1	Worm gear	63	20307	1	Bushing
27		1	Key 8 X 16	64	20301	2	Knob
28	20217	2	Bushing	65		1	Screw M5 X 12
29	20218	1	Gear	66		1	Oil cup
30	20219	1	Gear	67	20246	1	Screw
31	20221	1	Gear	68	20308	2	Pin
32	20216	1	Bushing bracket	69		1	Locked handle
33		2	Retainer ring 24	70		4	Screw M8 X 50
34		1	Retainer ring 35	71		2	Taper pin 6X 60
35		2	Key 4 X 8	72			
36		3	Screw M4 X 12	73			
37	20202	1	Gear	74			



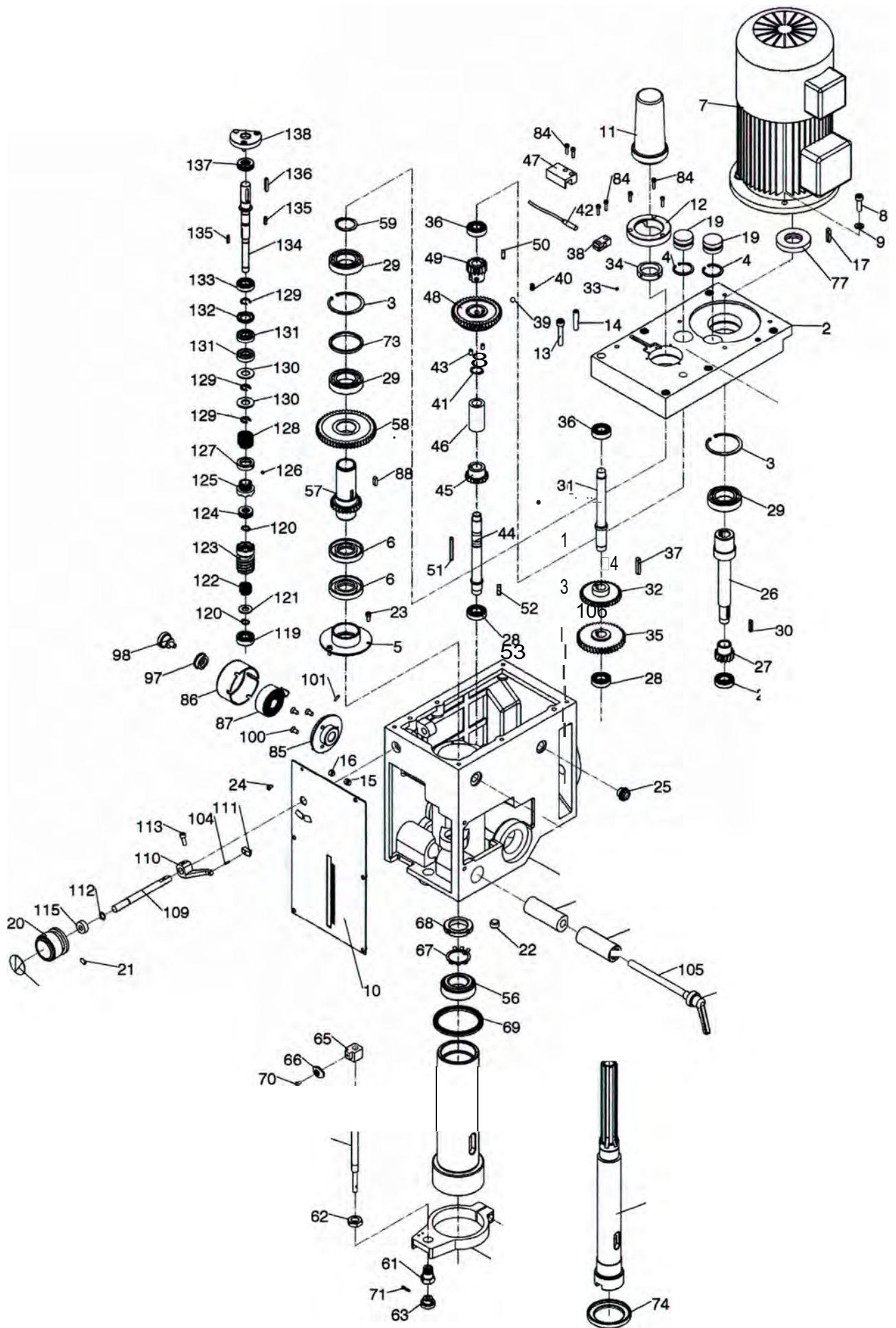

### Head parts for spindle power feed

No	Qty.	Code	Name	No	Qty.	Code	Name
1	1	20010B	head body	37	1	6x14	key
2	1	20011B	head body cover	38	1		The probe holder
3	2	62	retaining ring	39	1	8	ball
4	2	35	retaining ring	40	1		spring
5	1	20018B	airtight base	41	1	18	retaining ring
6	2	45x35x10	airtight ring	42	1		searching unit
7	1	5-100Hz	motor	43	2	M6x8	screw
8	1	M8x25	screw	44	1	20107V	III shaft
9	1	8	washer	45	1	20110-2-B	gear
10	1	20201	plate	46	1	20107V.1	bush
11	1	20304-1B	arbor bolt cover	47		20304V2	Accused of head cover
12	1	20304-02	arbor bolt cover base	48	1	20113-B	gear
13	6	M8x45	screw	49	1	20115-B	gear
14	6	8	pin	50	1	6x18	key
15	1	M10x10	screw	51	1	5x50	key
16	1	M10x8	screw	52	1	6x22	key
17	1	8x28	key	53	1	20019	spindle sleeve
18	1	ZG3/8	bolt	54	1	20104B	spindle
19	2	20020B	cap	55	1	33009-P5	bearing
20	1	20307B	speed lever	56	1	33007-P5	bearing
21	2	M6x12	screw	57	1	20114-V	splined sleeve
22	1	ZG3/8	oil plug	58	1	20116-B	gear
23	3	M5x10	screw	59	1	35	retaining ring
24	6	M4x8	screw	60	1	20012	feed base
25	1	M18x1.5	oil pointer	61	1	20128	support base
26	1	20105B	I shaft	62	1	20129	nut
27	1	20105-1-B	gear	63	1	20130	knob
28	3	6003-P5	bearing	64	1	20131	graduated rod
29	3	6007-P5	bearing	65	1	20021	fixed bolt
30	1	5x25	key	66	1	20132	scale board
31	1	20106V	II shaft	67	1	35	lock washer
32	1	20110V	gear	68	1	M35x1.5	lock nut
33	4		Magnetic beads	69	1	20308	rubber washer
34	1	20304V	spacer bush	70	1	M4x8	screw
35	1	20106-1-B	gear	71	1	3x18	split pin
36	2	6202-P5	bearing	72	1	M8x30	bolt

No	Qty.	Code	Name	No	Qty.	Code	Name
73	1	20024B	separating ring	119	1	6201	bearing
74	1	20133B	oil tight cover	120	2	12	retaining ring
75		3		121	1	12	washer
76				122	1	20209	spring
77	1	60x35x10	oil seal	123	1	20207A	worm shaft
78	1	20307C2	Plate	124	1	51101	bearing
79		2		125	1	20208B	clutch base
80				126	3	M4	screw
81				127	1	M22	locked out
82	1			128		20205B	spring
83	2			129		20108A	fixed sleeve
84	7	M4x20	screw	130		20103A	washer
85	1	20118	spring base	131	1	15x32x7	oil seal
86	1	20123	spring cap	132	1	20103A	retaining ring
87	1	20122	spring plate	133	1	6002	bearing
88	1	6x18	key	134	1	20213A	l shaft
97	1	203063	washer	135	2	4x16	key
98	1	203066	bolt	136	1	5x30	key
100	3	M6x12	screw	137	1	51103	bearing
101	2	3x12	pin	138	1	20104A	flange
104	1	3x12	pin	139	3	M5x16	screw
105	1	20124B	fixed bolt	140	1	17	retaining ring
106	1	20203B	fixed tight block	141	1	20212A	gear
107	1	20202B	fixed tight block	142	1	20109A	quill
108	1		adjust handle	143	1	20214A	lever shaft
109	1	20125B	lever shaft	144	1	12x2.4	O-airtight
110	1	2022-1B	lever	145	1	20250	flange cover
111	1	20204-2B	lever bracket	146	2	M3x8	screw
112	1	12	retaining ring	147	1	12	retaining ring
113	1	M6x16	screw	148	1	8	steel ball
115	1	12x22x8	oil seal	149	1		spring
116				150	1	M6x18	screw
117				151	1	20201	speed lever
118				152	1	20303	label

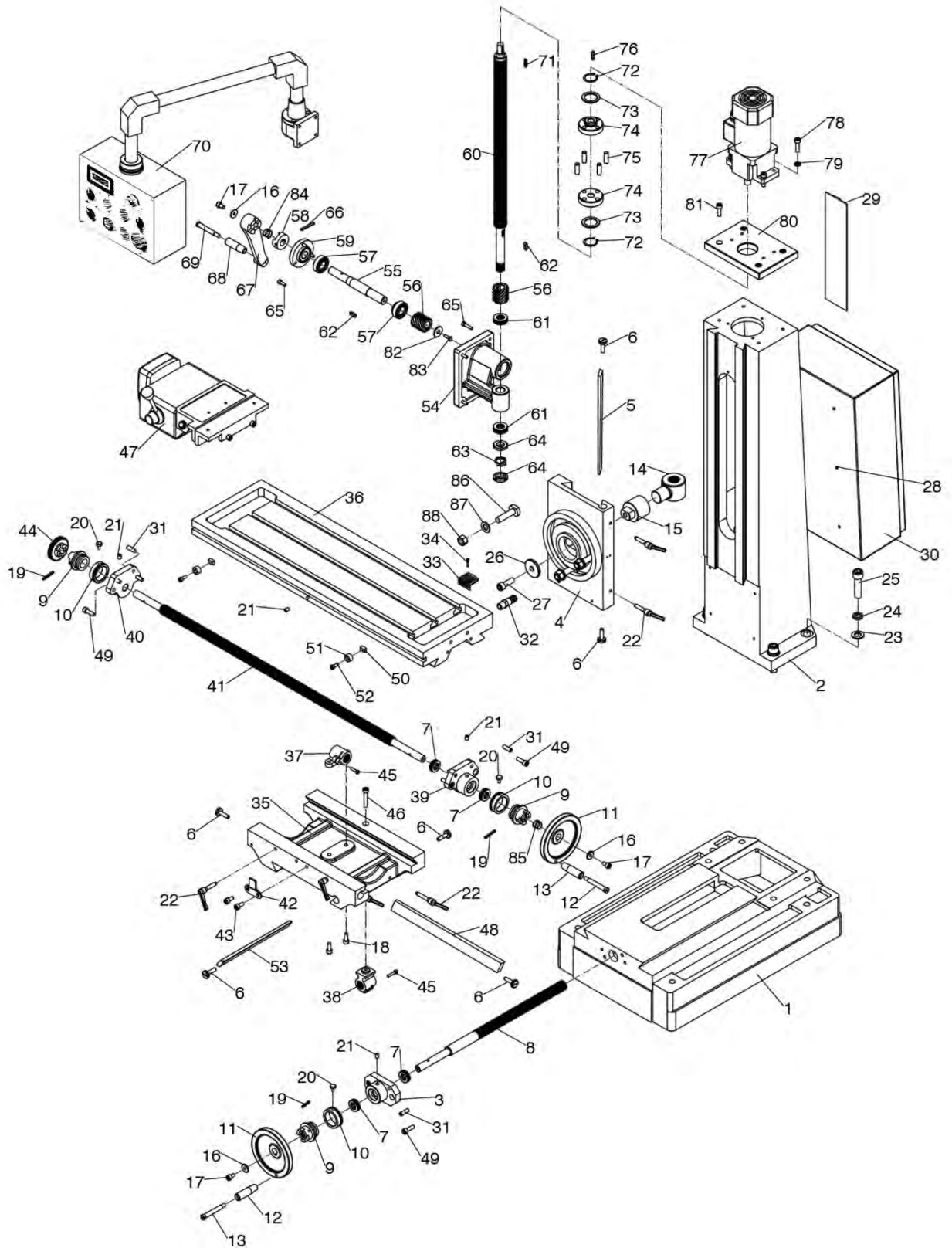

No	Qty	Code	Name	No	Qty	Code	Name
1	1	10010	base	45	2	M5X20	screw
2	1	10013	column	46	1	M8X45	screw
3	1	10021	square flange	47	2	135LBS	(Power feed)
4	1	10016	raise and lower base	48	1	10022	gib strip
5	1	10025	gib strip	49	6	M8X25	screw
6	6	10106	screw	50	2	10108	movable fixed block
7	4	51103	bearing	51	2	10109	fixed block support
8	1	10104	table screw	52	2	M6X16	screw
9	3	10102	dial clutch	53	1	10023	gib strip
10	3	10111	graduated plate	54	1	10017	raise and lower base
11	2	10301	wheel	55	1	10113	shaft
12	2	20305-1B	turn handle	56	2	20109	gear
13	2	20305-2B	screw	57	2	6004	bearing
14	1	10024	nut	58	1	450209	dial clutch
15	1	10117	nut bracket	59	1	10015	flange
16	3	6	washer	60	1	10016	raise and lower screw
17	3	M6X16	screw	61	2	51104	bearing
18	2	M8X25	screw	62	2	6 X 20	key
19	3	5X35	pin	63	1	20	lock washer
20	3	10107	screw	64	2	M20X1.5	lock nut
21	4	8	oil cup	65	7	M6 X 25	screw
22	6	M8	fixed handle	66	1	5 X 40	pin
23	4	16	washer	67	1	10018	head handle
24	4	16	washer	68	1	10018.1	turn handle
25	4	M16X60	bolt	69	1	10018.2	Screw M10
26	1	10120	washer	70	1		Electrical box
27	1	M12X35	screw	71	1	5X22	key
28	6	M6x12	screw	72	2	30	retaining ring
29	1	10124	protecting cover	73	2	10152	washer
30	1	10119	Electrical box	74	2	10150	
31	6	8X30	pin	75	4	10151	
32	1		Pipe joint	76	1	5X25	key
33	1		Filter screen	77	1	Motor	90W220V60Hz1ph
34	2	M3X25	table nut	78	4	M8X25	screw
35	1	10011	center base	79	4	8	washer
36	1	10012	table	80	1	10014	motor mount
37	1	10202	table nut	81	4	M8 X 25	screw
38	1	10203	table base nut	82	1	8	washer
39	1	10020	right flange	83	1	M8 X 25	screw
40	1	10019	left flange	84	1	450209.2	Spring
41	1	10103	table screw	85	1	10102.2	Spring
42	1	10105	fixed block	86	3	M14x55	T-screw
43	2	M8x16	screw	87	3	14	washer
44	1		Gear	88	3	M14	nut

PACKING LIST FOR

GEARED HEAD DRILLING & MILLING MACHINE Super Lux Plus

Series No :		Dimension :			
G/W :		N/W :			
No.	Name	Spec	Model	Quantity	Remark
1	Milling & drilling machine		Super Lux Plus	1	
2	Draw bar	M12		1	
3	Adapter	MT3/MT2		1	
4	Taper shank for drilling chuck	MT3/B16		1	
5	Drilling chuck	Φ1~Φ13		1	
6	Arbor			1	
7	T slot bolt	M12×55		2	
8	Washer	12		2	
9	Nut	M12		2	
10	Inner hexagonal spanner	2.5/3、4、5、8		5	
11	Tilted wedge			1+1	
12	Spanner	17-19/19-22		1+1	
13	Oil gun			1	
14	Instruction Manual			1	
15	Certificate of inspection			1	
16	Packing list			1	

Packing inspector\_\_\_\_\_

Date\_\_\_\_\_